

A区間 2400m (左回り2周)
D区間 3430m
速度 490m/分
規定タイム 7分

1 ブラシ障害

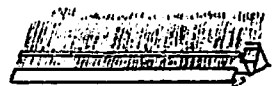

2 電柱オクサー

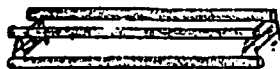

7 テーブル (電柱)



8 ブラシ障害

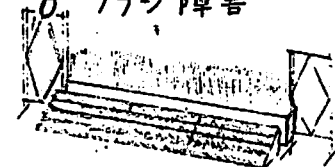

3 電柱バンケット

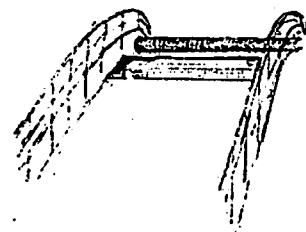

4 電柱ドラム

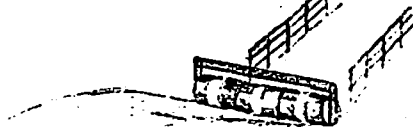

9 フェンス障害
A-B-C

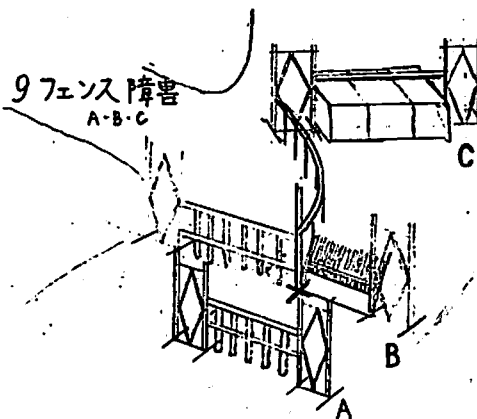

10 トラケネ A-B

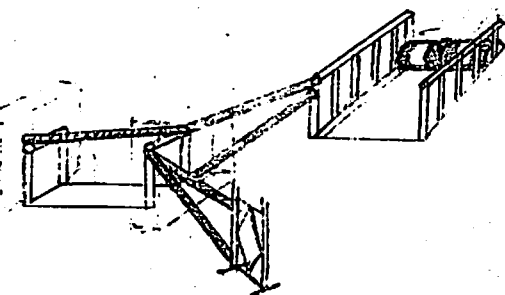

5 山型三段

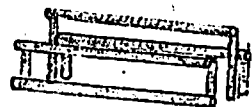

6 自然木



11 生垣

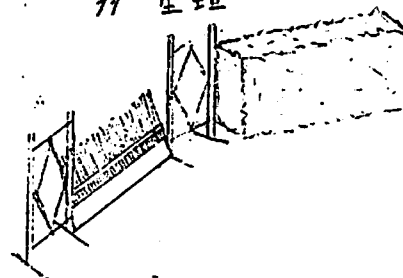

12 バウス A-B

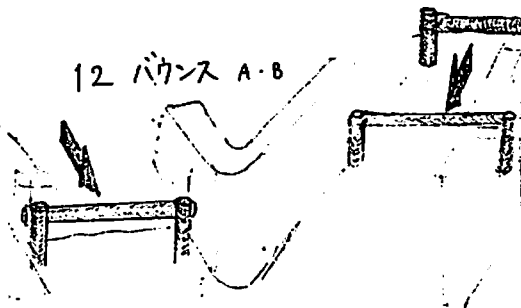

13 スキージャンプ

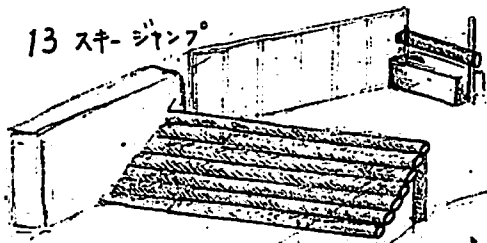

14 木飛び込み A・B

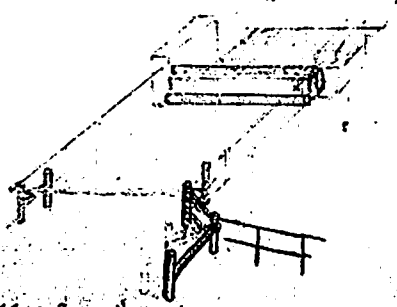

15 レンガ障壁

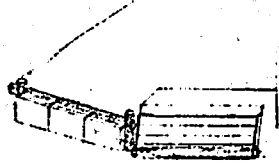

16 ピアバンク

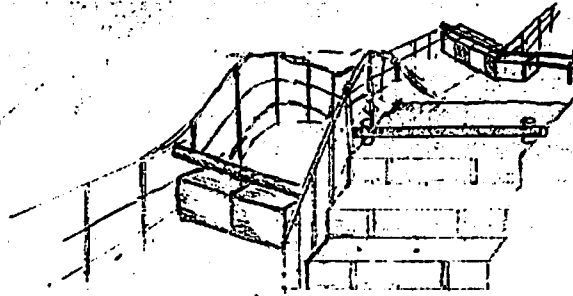

18 花壇

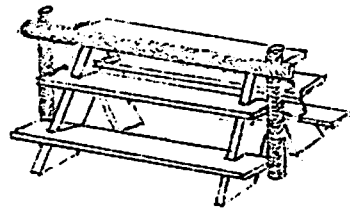

17 スキージャンプ

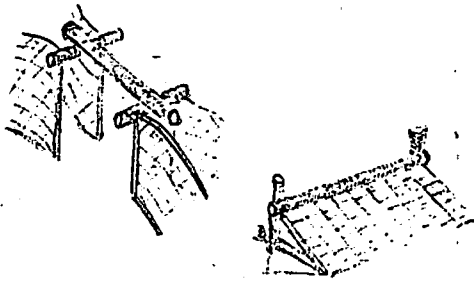

19 電柱オクサー (竹柵)

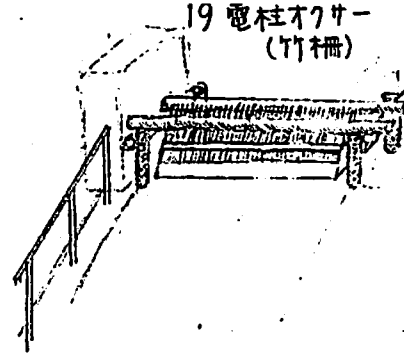

20 ダブルバンク A・B

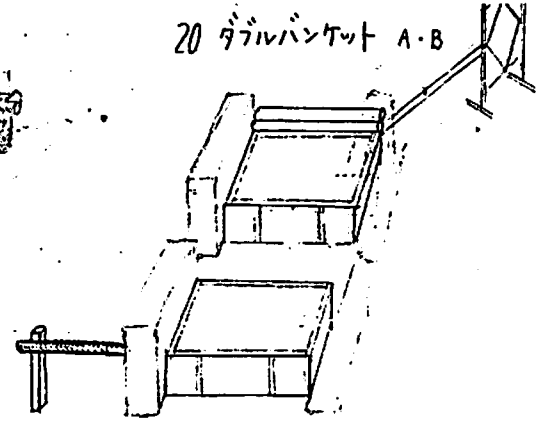

21 乾燥電柱

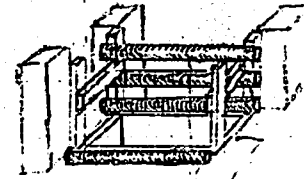

22 リバプール

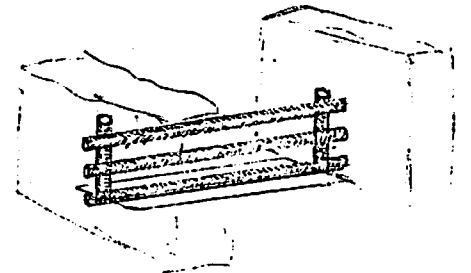

23 コフィン A・B

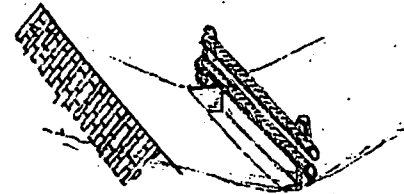

24 ツルピン

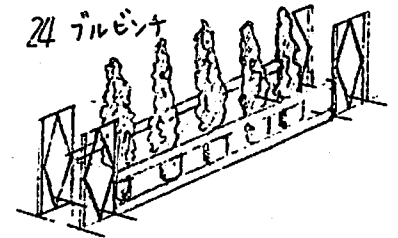

25 ビアダル

